



*BRITT · ÇAYLA · MYA  
SELMA · ZOE · ELIN · IRIS · MALIN  
· OPRAH · RAILA · VIVIAN*

CREO®  
KITCHENS

**100%**  
**MADE IN ITALY**  
**WITH LOVE**

**CREO Kitchens** da il suo più cordiale benvenuto a tutti coloro che desiderano uno spazio cucina e living belli da vedere, semplici da utilizzare, ricchi di finiture e colori di tendenza, caratteristiche raccolte in questo catalogo, ricco di idee e suggerimenti, grazie alla vasta gamma di modelli e accessori proposti e all'equilibrato rapporto tra la qualità e il prezzo estremamente interessanti. CREO Kitchens mette sempre voi al centro dei suoi progetti.

**CREO Kitchens** offers its warmest welcome to all those looking for a kitchen and living room area that is beautiful to look at, simple to use and rich in fashionable finishes and colours. This is what you'll find in this catalogue, which is packed with examples and suggestions, thanks to our vast range of models and accessories with excellent price/quality ratios. CREO Kitchens always places you at the centre of its designs.



## CREO KITCHENS ...

### CREO KITCHENS ... INFINITE ALCHEMIES INFINITE ALCHEMIE

**Un nuovo marchio**, un contenitore di emozioni, un punto di riferimento dedicato ad un pubblico moderno, attento, open-minded. CREO Kitchens con te realizza infinite alchimie, anche tu come noi sei amante dell'originalità, della ricercatezza, della personalizzazione, dell'anticonformismo, giovani nell'età o semplicemente nel gusto e sai scegliere prodotti che sanno realizzare le tue aspettative, accomunati dal fil rouge del giusto rapporto tra la qualità e il prezzo.

**A new brand**, a container for emotions, a point of reference dedicated to a modern, demanding and open-minded public. CREO Kitchens creates infinite alchemies with you. Just like us you love originality, refinement, customisation and anti-conformism. You are youthful in age or in taste and you know how to choose products that meet your expectations, products that offer the right price/quality ratio.

*Creatura ... Creatività ... Creo*



*Alla ricerca di nuove Suggestioni*  
**INSPIRATIONS**

**FINDING NEW INSPIRATIONS**



*Inspirations...*  
*emozioni in libertà*

**Un progetto in continua evoluzione**, che comprende lo studio di un particolare mood capace di esprimere un nuovo concetto di ambiente cucina e living contemporaneo, in un'atmosfera Made in Italy che sa cogliere le infinite ispirazioni del vivere cosmopolita, in grado di rievocare suggestivi angoli di mondo in un mix di stili originali ed esclusivi, riproponendoli per tuo vivere quotidiano.

**A design that is continuously evolving**, one that captures a special mood able to express a new concept in contemporary kitchen and living room spaces. It creates an atmosphere of 'Made in Italy' quality that draws inspiration from the infinite facets of cosmopolitan living. Able to evoke inspiring corners of the world in a blend of original and exclusive styles, it reinvents them to suit your daily life.

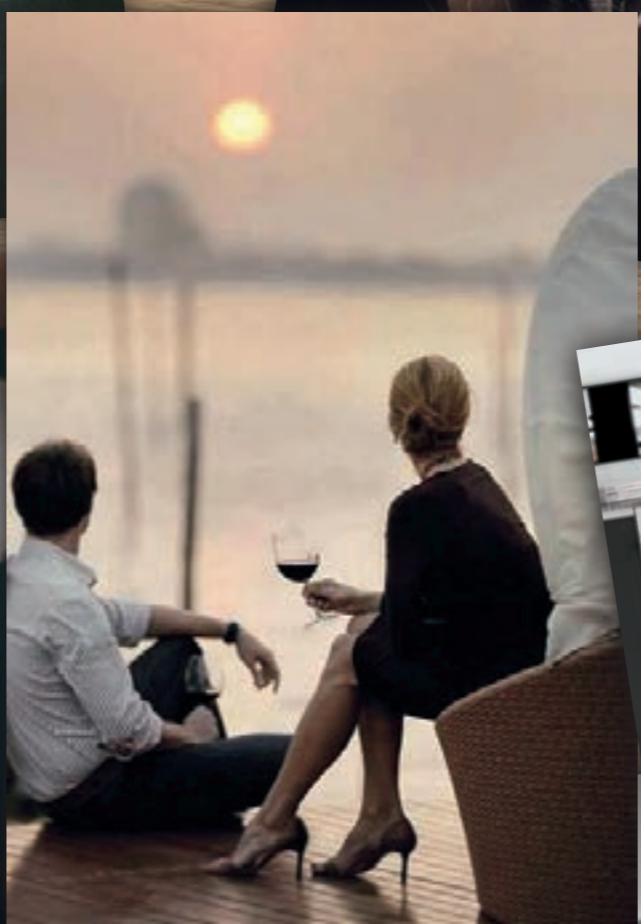

*Loving*  
**100% MADE IN ITALY  
WITH LOVE**

**100% MADE IN ITALY WITH LOVE**

In CREO Kitchens vive la passione tipicamente Made in Italy di creare nuove tendenze dando forma alle idee, alla creatività, al gusto, nella continua ricerca di uno stile fatto di rispetto e condivisione con la nostra storia e il mondo globale. Qualità, convenienza, soddisfazione dell'acquirente finale sono valori alla base dei nostri sforzi industriali e progettuali.

CREO Kitchens keeps alive the typically Italian passion for creating new trends, giving shape to ideas, creativity and taste in the continuous search for a style that respects and shares our history with the world. Quality, convenience and customer satisfaction are values that lie at the basis of both our industrial commitments and design choices.

*Loving...  
... we love Creo Kitchens*



*Trend*

## I NUOVI TREND CONTEMPORANEI

NEW CONTEMPORARY TRENDS

**Ognuno può trovare** in CREO Kitchens la formula del proprio stile esprimendolo in un personalissimo mix di originali ed esclusive soluzioni compositive. CREO Kitchens mette assieme codici diversi secondo un piacevole gioco di uguali e contrari, contemporaneo e tradizionale, colorato e neutro, freddo e caldo, lucido e opaco, per realizzare trend assolutamente unici e personalizzati.

**Everyone can find** the formula to express their own style in CREO Kitchens, using a highly personalised mix of original and exclusive compositional solutions. CREO Kitchens combines different codes together in a playful game of matches and opposites, contemporary and traditional, colourful and neutral, hot and cold, polished and matt, in order to create completely unique and customised looks.



**Ogni elemento attorno** a noi contribuisce a costruire la realtà in cui viviamo. CREO Kitchens si fa interprete delle tue emozioni in cucina e nel living e le rende autentiche.

**Every element around us** contributes to creating the world we live in. CREO Kitchens interprets your emotions in the kitchen and living room and makes them real.

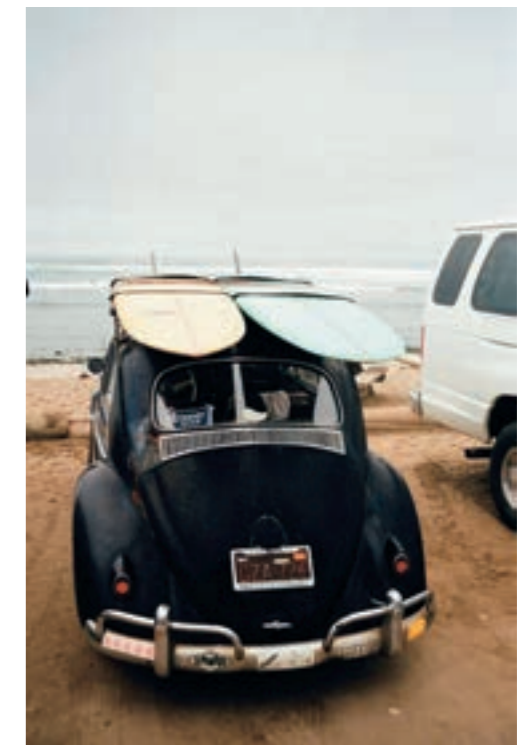

**CREO Kitchens diventa icona** di precisi lifestyle, per ogni tua esigenza. Tavole da surf e maggiolino esprimono libertà, voglia di natura e di convivialità, esigenze che trovano espressione anche nelle nuove tecnologie di comunicazione e nei network, attento a queste nuove dinamiche sociali CREO Kitchens ti invita nella sua community, chattando, bloggando, twittando per contattarci per ogni tua necessità, richiesta e consiglio.

**CREO Kitchens becomes an icon** for precise lifestyles, to meet all your needs. Surfboards and VW Beetles express freedom, a love of nature and sociability. These qualities can also be found in new communication technologies and social networks. With this in mind CREO Kitchens invites you to join its community: chat, log on, blog, and twitter with us to tell us about your needs, requests and advice.

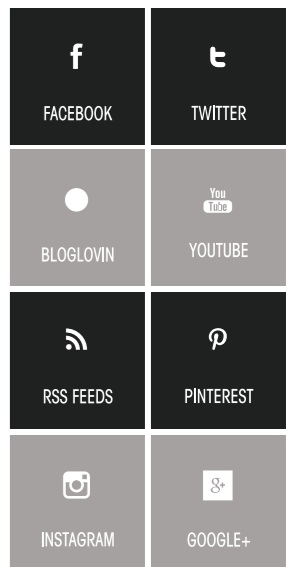

*Sensitivity*

**NEW SENSITIVITY FOR ENVIRONMENT**

## **SENSIBILITA' VERSO L'AMBIENTE**

CREO Kitchens agisce con risposte concrete alle esigenze declinate a livello mondiale per la sostenibilità ambientale. Un impegno che si manifesta attraverso l'utilizzo del Pannello Ecologico e di materiali ecocompatibili per la realizzazione dei suoi prodotti, nell'attenta gestione razionale delle risorse e nel continuo miglioramento della metodologia produttiva come l'utilizzo di un importante impianto fotovoltaico, che garantisce quotidianamente il minimo impatto ambientale per la produzione di energia.

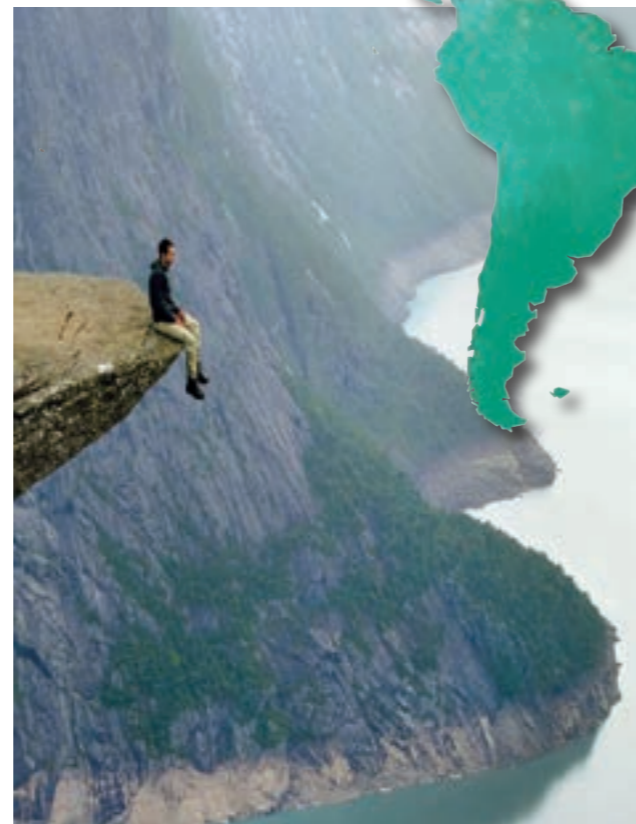
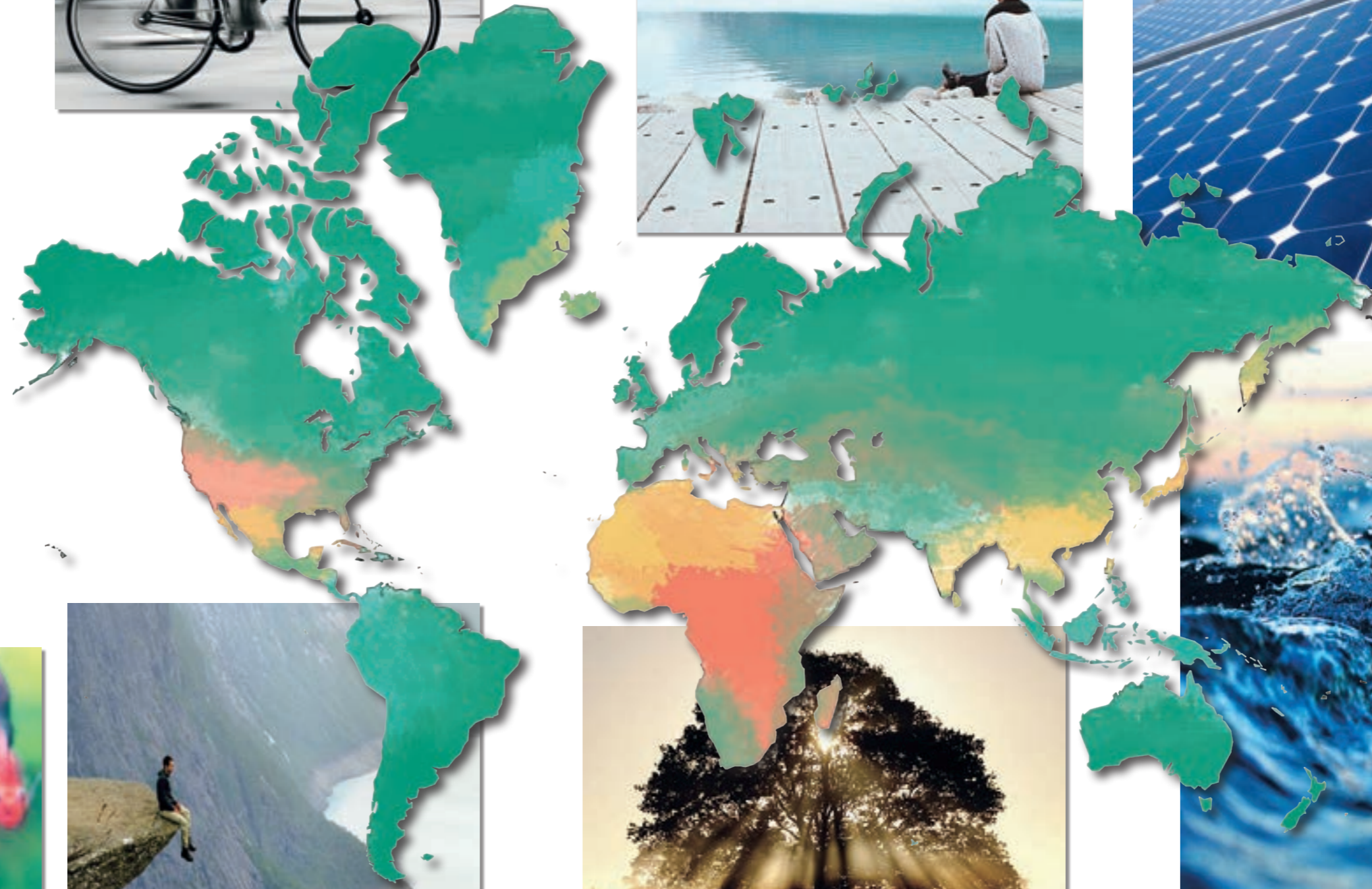

CREO Kitchens provides concrete responses to worldwide calls for environmental sustainability. This commitment takes the form of the use of Ecological Panels and eco-compatible materials for making our products, the rational management of resources and continuous improvements in the manufacturing process. This includes the use of a large photovoltaic system at our plant, which guarantees minimum environmental impact for energy generation every day.

*Brand*  
**CUCINE PER  
TUTTI I GUSTI**

**KITCHENS FOR ALL TASTES**



**Non basta che una cucina sia bella,** bisogna che riesca ad entrare in armonia con le tue idee e le tue richieste di funzionalità e creare la giusta atmosfera nell'ambiente più amato della tua casa. CREO Kitchens propone una vasta e completa gamma di modelli con ante liscie o a telaio, con finiture e colori contemporanei e tradizionali e un vasto assortimento di accessori per soddisfare ogni tua esigenza.



**It is not enough for a kitchen to be beautiful,** it also needs to be in harmony with your ideas and your need for functionality in order to create the right atmosphere in the most loved room in the home. CREO Kitchens offers a vast and comprehensive range of models with smooth or frame doors, with contemporary and traditional colours and finishes, as well as a wide assortment of accessories, in order to satisfy your every need.





**Per mantenere alto nel tempo** l'amore per la tua nuova cucina CREO Kitchens, i nostri tecnici hanno testato e valutato attentamente per te ogni singolo particolare costruttivo, per verificarne l'affidabilità, la sicurezza, l'ergonomia e la durata.

In CREO Kitchens sosteniamo la cultura del fare mettendo con passione a disposizione il nostro know-how per sviluppare soluzioni progettuali personalizzate per interpretare con flessibilità e creatività i tuoi spazi, con risultati certi e condivisi.

Essere competitivi per noi di CREO Kitchens non è solo riuscire a dare idee e ispirazioni per farti desiderare i nostri prodotti, noi vogliamo far realizzare i tuoi sogni, ed è per questo che abbiamo concentrato gran parte delle nostre forze programmatiche sul giusto rapporto tra qualità e prezzo dei nostri prodotti. Grazie alla condivisione delle nostre esperienze e quelle dei progettisti e dei nostri fornitori, siamo riusciti a realizzare una filiera in cui utilizzando materiali e finiture di alta qualità, riusciamo a produrre modelli dall'alto contenuto qualitativo, estetico e funzionale, competitivi nel prezzo.

*Quality*

## QUALITA' TOTALE E CONVENIENZA

**OVERALL QUALITY AND CONVENIENCE**



**In order to make sure your love** for your new CREO Kitchen lasts, our technicians have tested and carefully assessed every single structural detail for you, to verify reliability, safety, ergonomics and long life.

Here at CREO Kitchens we support the culture of making, placing our know-how at your disposition for developing personalised design solutions that interpret your spaces with flexibility and creativity for concrete and shared results.

For us here at CREO Kitchens being competitive doesn't mean just giving you ideas and inspiration to make you want our products. We want to make your dreams come true, and this is why we have dedicated much of our planning resources to finding the right balance between quality and price for our products. By sharing our experience with that of our designers and suppliers, we have managed to create a supply chain that allows us to use high quality materials and finishes. This allows us to produce models that are high quality, aesthetic and functional as well as being competitively priced.





Per CREO Kitchens garantire la consegna rapida e completa del prodotto scelto o agire velocemente e con professionalità alle esigenze del venditore o del consumatore sono priorità inderogabili, perchè ci identifichiamo sempre con le aspettative e le richieste del cliente. Questo viene realizzato mediante la capillare e organizzata rete distributiva e alla competenza professionale della nostra forza vendita e commerciale.

For CREO Kitchens, guaranteeing the rapid and complete delivery of your chosen product and responding rapidly and professionally to the requirements of the retailer or consumer are our utmost priority. We identify with your expectations and demands. This is achieved via our well organised distribution network and the professional skills of our sales team.

*Service*

## SERVIZI RAPIDI E COMPETENTI

**RAPID AND COMPETENT SERVICE**



## RIVENDITORI E FORNITORI PRESTIGIOSI

**PRESTIGIOUS RETAILERS AND SUPPLIERS**



La qualità, ricercata in ogni dettaglio, nasce dalla grande tradizione artigianale italiana e dalla conoscenza profonda della tecnologia industriale. Grazie ad una squadra qualificata, formata da prestigiosi partner per le forniture e da una rete capillare di rivenditori ufficiali selezionati tra i migliori negozi nei più importanti centri, si garantisce quel valore aggiunto che è la garanzia di qualità e durata dei prodotti CREO Kitchens.

The quality and attention to detail we are able to offer is the result of the great Italian tradition of craftsmanship and our profound understanding of industrial technology. Only thanks to a skilled team made up of prestigious suppliers and a wide network of official retailers selected from among the best stores in the most important cities, are we able to offer the added value that is the CREO Kitchens guarantee of quality and long life.

# AVANGUARDIA TECNOLOGICA

CUTTING-EDGE TECHNOLOGY

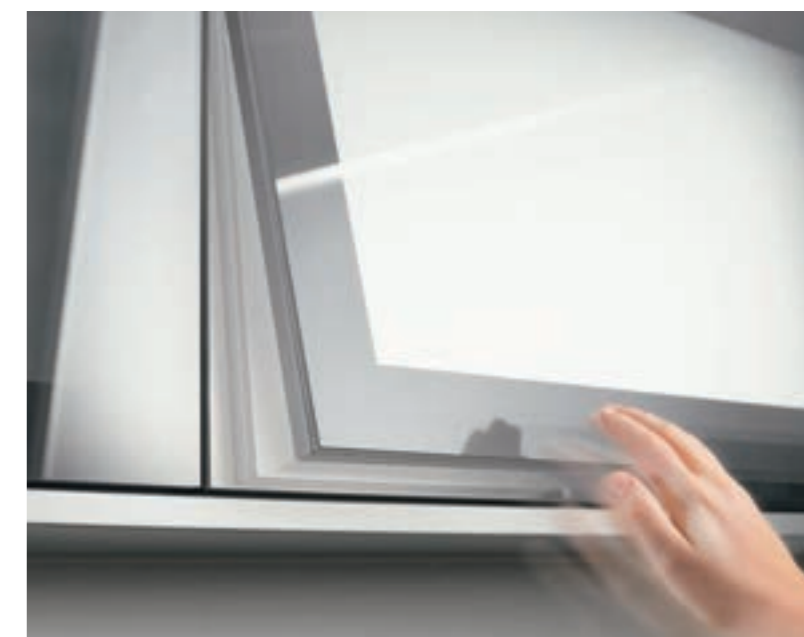

**CREO Kitchens realizza le proprie cucine** seguendo rigidi standard che contribuiscono a farne un'azienda modello dal punto di vista produttivo, grazie al costante sviluppo di soluzioni tecnologiche avanzate, all'aggiornamento professionale del personale, patrimonio indispensabile per determinare le linee guida che definiscono gli obiettivi del brand.

**CREO Kitchens makes its kitchens** according to strict standards that contribute to its reputation as a model manufacturer. These are made possible thanks to the constant development of cutting-edge technological solutions and the training of personnel. It is the latter after all that are our greatest resource and that allow us to determine our guidelines and reach our objectives.



## PERFECTING MOTION

Le guide estraibili e i sistemi di ammortamento delle chiusure dei mobili CREO Kitchens sono della Ditta BLUM, una delle più importanti aziende al mondo del settore. Il sistema di guide a scomparsa TANDEM offre massimo comfort di utilizzo, facendo scorrere con facilità cassetti e cestoni anche molto pesanti BLUMOTION è il sistema ammortizzante che permette la chiusura dei mobili in modo dolce e silenzioso indipendentemente dalla forza esercitata e dal peso dell'anta o del frontale. I prodotti Blum entusiasmano per la loro funzionalità e l'alta qualità. I progetti nascono dalla raccolta di dati con l'osservazione dell'utilizzo delle cucine in tutto il mondo. Per assicurare la qualità durante lo sviluppo, i tecnici si avvalgono di simulazioni al computer e test con prototipi. In Blum tutto gira intorno al movimento, l'obiettivo è la soddisfazione duratura dei clienti CREO Kitchens, con prodotti che convincono per il funzionamento impeccabile, l'apprezzato design e la lunga durata, standard qualitativi applicati anche ai servizi.

## PERFECTING MOTION

The extractable guides and soft closure systems on CREO Kitchens cabinets are made by BLUM, one of the biggest companies worldwide in this sector. The TANDEM fully-integrated guide rail system offers maximum comfort of use, allowing even very heavy drawers and deep drawers to slide easily. BLUMOTION is a soft closure system that allows cabinets to be closed softly and silently independently of the level of force applied or the weight of the door or front panel. Blum products are popular because of their functionality and high quality. They are the result of data gathered and observations made on kitchen use worldwide. In order to ensure quality during the development stage, Blum technicians make use of computer simulations and prototype testing. At Blum everything revolves around movement, the aim is to provide CREO Kitchen customers with long-lasting satisfaction. This is achieved through products with impeccable functionality, good design and long life, quality standards that are also applied to our services.

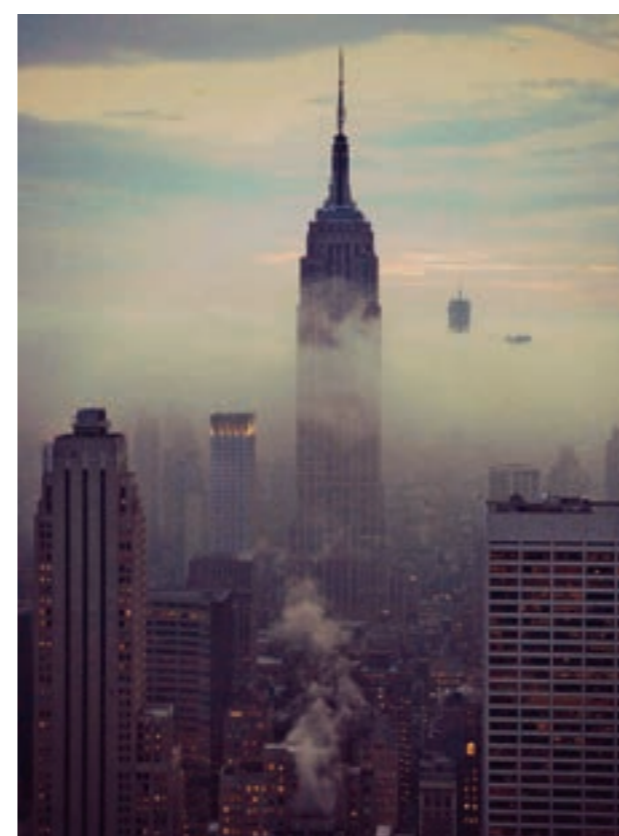

*Living*

## NON SOLO CUCINA ...

NOT ONLY KITCHEN ...

**Ambienti cucina e zone living**, possono essere interpretati con flessibilità e continuità sia nello stile che nella funzionalità. CREO Kitchens cambia le regole dell'abitare e concepisce una casa che diventa perfetta per il tuo modo di vivere, dando la possibilità di concepire e arredare spazi del vivere domestico senza soluzione di continuità.

**Kitchen areas and living room spaces** can be interpreted with flexibility and continuity both in terms of style and functionality. CREO Kitchens changes the rules of living and designs a house that is perfect for your way of life, giving you the possibility to design and furnish your domestic spaces without any loss of continuity.

# Cucine Moderne

## MODERN KITCHENS

Creo Kitchens offre un'ampia gamma di modelli e di soluzioni estetiche, nella costante ricerca della qualità e la cura di ogni dettaglio, per soddisfare i gusti di chi ama ambienti innovativi e funzionali.

Le cucine moderne Creo Kitchens coniugano colore e linearità di forme, praticità e design, caratterizzandosi non solo per la qualità dei materiali e la rifinitura dei particolari, ma anche per la loro elegante ed attuale originalità, per creare ambienti che rispondano alle tue esigenze.

Creo Kitchens offers a wide range of models and aesthetic solutions. In a constant search for quality and minute attention to detail, it aims to satisfy those that love innovative and functional spaces.

Creo Kitchens modern models combine colour with linear forms, practicality and design. The company is characterised not only by the quality of its materials and detailed finishing but also by the elegant and contemporary originality of its products, allowing you to create spaces that meet all your needs.





*Gayla* *passioni belle*  
ANTA IN ALKORCELL *da vivere*



**Il modello Gayla** con anta in Alkorcell, un materiale atossico ed ecocompatibile, nelle finiture legno e color opaco fortemente caratterizzanti, permette originali proposte compositive e suggestivi accostamenti stilistici.

**The Gayla model** features doors in Alkorcell, a non-toxic and eco-friendly material. The highly characteristic wood finishes and matt colours provide scope for original compositions and charming style combinations.



*Gayla*



*Britt* realizza i tuoi desideri  
ANTA IN POLIMERICO FINITURA LEGNO, LUCIDO E OPACO

# Britt



**Il modello Britt crea spazi domestici** lineari, essenziali ed originali, con infinite possibilità di personalizzazione. Britt si trasforma nella protagonista assoluta del tuo vivere quotidiano.

**The Britt model creates** linear, minimalist and original domestic spaces with infinite possibilities for customisation, placing you at the centre of your daily life.









**Grazie alla particolare stonatura** sui quattro lati dell'anta e alle attuali finiture del polimerico proposto nei colori lucidi e opachi e nelle raffinate proposte legno, Britt crea ambienti conviviali, caldi ed accoglienti senza rinunciare alla funzionalità.

**Thanks to the special rounding** applied to all four sides of the door and the contemporary polymer finishes available in both polished and matt colours as well as refined wood finishes, Britt creates warm, convivial and welcoming spaces, without compromising on functionality.

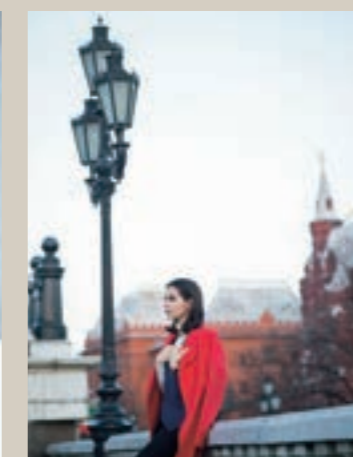

*Britt*

# *Mya* gioco di superfici

ANTA IN ALKORCELL





**Con un equilibrato gioco di volumi** la cucina Mya rilegge con spirito contemporaneo le atmosfere calde e rasserenanti della tradizione classica. La particolare finitura dell'anta a telaio in Alkorcell, conferisce alle essenze in legno spazzolato una sensazione tattile e visiva di grande naturalezza.

**With its well-balanced play of volumes** the Mya kitchen is a contemporary re-reading of the warm and reassuring atmospheres of the classical tradition. The special finish of the frame door in Alkorcell provides highly natural tactile and visual sensations.



*Mya*





**Le emozionali soluzioni estetiche** contemporanee, semplici e razionali, garantiscono risultati compositivi originali, grazie anche all'ampia modularità prevista e soprattutto all'anta dalla pregiata lavorazione.

**The emotional aesthetic solutions**, both simple and rational, guarantee original compositions, also thanks to the extensive modularity of the system and above all to the high quality finish of the doors.



*Mya*



*Selma* *convivialità e relax!*  
ANTA IN MASSELLO DI FRASSINO LACCATO



**Modello caratterizzato da un' anta a telaio da 22 mm**, dalla pregiata lavorazione per un design pulito ed attualissimo nei toni delicati dei colori laccati su frassino a poro aperto. Il tradizionale concetto di anta a telaio viene riletto e aggiornato, con la speciale maniglia che nasce dalla raffinata sagomatura del traverso superiore.

**This model is characterised by a 22 mm frame door**, a clean and contemporary design and open pore ash lacquer finishes in delicate colours. The traditional concept of a frame door is reinterpreted and updated in Selma, with a special handle created from the profile of the upper crossbar.





# Selma





**Innovativa ed elegante**, Selma trasmette emozioni con le sue laccature raffinate e moderne che personalizzano e danno eleganza con preziosi dettagli di luce. La conformazione dell'anta a telaio e la maniglia incorporata, ne valorizzano la leggerezza e la praticità, per arredare con stile la propria cucina e la zona living.

**Innovative and elegant**, Selma evokes emotions with its refined and modern lacquers, which render any space personal and elegant with precious plays of light. The structure of the frame door with recessed handle enhances the lightness and practicality of the model, allowing you to furnish your kitchen and living room in style.



*Selma*



*Zoe* cucina d'autore  
ANTA IN ACRILICO LUCIDO E OPACO



**Materiali pregiati e superfici differenti** si coniugano con armonia in un raffinato insieme contemporaneo. L'anta in acrilico di Zoe definisce uno stile finemente moderno, raffinatamente armonioso e contemporaneo, inseribile in qualsiasi tipologia compositiva e contesto architettonico.

**Valuable materials and different surfaces** are harmoniously combined into a refined contemporary assembly. Zoe's acrylic doors define a fine modern style, refined and harmonious, which can fit into any composition and architectural context.



*Zoe*



# Zoe

**Ogni composizione garantisce** un felice connubio tra praticità d'uso e soluzione estetica. I moduli a giorno creano nuovi spazi e forme per cucine dinamiche e creative.

**Every composition guarantees** a happy compromise between practicality and aesthetics. The open modules create new spaces and shapes for a dynamic and creative approach to the kitchen.



# Cucine Classiche

## CLASSIC KITCHENS

Le proposte del mondo **Creo Kitchens** per le cucine classiche ripropone il gusto e il calore delle forme tradizionali e della naturalezza del legno abbinato ad una serie esclusiva di finiture e colori per cucine belle e funzionali, complete di tavoli, sedie e complementi d'arredo in linea, al fine di rendere l'ambiente della vostra cucina un ambiente unico.

**Creo Kitchens' range** of classic kitchens revives the taste and warmth of traditional shapes and the natural look of wood combined with an exclusive series of finishes and colours. The result is a range of beautiful and functional kitchens complete with tables, chairs and matching furnishings, all designed to turn your kitchen into a refined and unique space.



ELIN

pg. 112



IRIS

pg. 96



MALIN

pg. 104



OPRAH

pg. 116



RAILA

pg. 100



VIVIAN

pg. 108

*Iris* semplicemente unica  
ANTA IN MASSELLO DI FRASSINO LACCATO







**Il modello Iris rilegge con spirito contemporaneo** i temi classici del vivere in cucina, creando sofisticate atmosfere che possono essere coniugate anche per la zona living. L'anta dal disegno tradizionale a telaio è arricchita da una serie di varianti colore attuali e di moda.

**The Iris model is a contemporary re-reading** of the classical kitchen lifestyle. It creates sophisticated atmospheres that can also be extended into the living room. The traditional frame door is enriched by a series of contemporary and fashionable colours.



*Iris*





**Un gioco di forme**, finiture e accostamenti per un racconto declinato alla tradizione in cucina con inedite proposte contemporanee. L'anta in telaio massello di frassino con bugna liscia impiallacciata frassino è resa raffinata ed esclusiva da una leggera linea curva cesellata nel telaio e dalle finiture a poro aperto e decapato poro aperto dalle raffinate e attuali colorazioni come bianco camelia, grigio polvere e corda decapé.

**A play of shapes**, finishes and combinations for a traditional kitchen with unusual contemporary features. The frame door in solid ash with smooth ash veneered central panel is made refined and exclusive by a light curved line chiselled into the frame.

It is available in open pore and pickled open pore finishes as well as in refined and contemporary colours such as camellia white, dust grey and pickled jute.



*Raila*





**Una cucina che ritorna alle vere radici** del prodotto tradizionale, dove la scelta di pregiati materiali e le loro attente lavorazioni, servono a realizzare cucine preziose e raffinate, legate in maniera indissolubile ai valori classici, che sono evidenziati in Malin dalla particolare cura dedicata alla realizzazione dei dettagli.

**This kitchen goes back to the true roots** of traditional kitchens. To the days when precious materials and careful craftsmanship were used to create precious and refined kitchens that were indissolubly linked to classical values. These values are highlighted in Malin by a close attention to detail.



*Malin*



# Vivian



**Dal tratto sobrio e chic** il modello Vivian nasce dall'attenzione posta nel disegno dei particolari e dei dettagli, che riescono a fondere in questo modello passato e presente per creare soluzioni estetiche e pratiche di grande prestigio e raffinatezza. L'anta dal proporzionato profilo del telaio viene proposta nelle esclusive finiture spazzolato e decapato e negli eleganti colori bianco, mielato e tortora.

**Sober and chic**, the Vivian model is the result of great attention to detail paid during the design stage. It manages to combine both the past and the present to create highly refined aesthetic and practical solutions. The well-proportioned door frame is available in exclusive brushed and pickled finishes and in the elegant colours white, honey and dove grey.









**Dalle linee tradizionali fortemente caratterizzate,** Elin riesce, grazie alla sua grande versatilità compositiva, a creare uno stile così originale da farsi attuale. Elin è un modello di cucina dall'aspetto nobile e raffinato, grazie ai tocchi preziosi delle finiture e alle qualità estetiche. L'eleganza senza tempo rendono Elin una cucina di tendenza per il suo caratteristico spirito internazionale che permette di creare spazi cucina e living dalla forte personalizzazione, senza per questo diminuire la funzionalità e la praticità tipici della contemporaneità.

**With its highly characteristic traditional lines** and excellent compositional versatility, Elin manages to create such an original style as to become contemporary. Elin is a kitchen model with a noble and refined look, provided by the precious touch of its finishes and its overall aesthetic quality. Timeless elegance makes Elin a fashionable kitchen. Its characteristically international spirit also allows for the creation of highly customised kitchen and living room areas that do not compromise on the functionality and practicality typical of contemporary products.

*Elin*





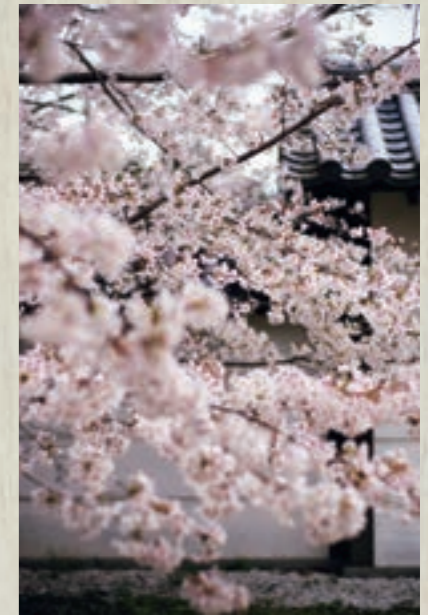

**La cucina Oprah con anta ornata a telaio** dalle linee classiche e raffinate, propone a chi ama il calore e le soluzioni estetiche dello stile tradizionale un tocco di originalità che conferisce alle composizioni una forte caratterizzazione e un senso di grande equilibrio formale che genera gratificazione e facilità d'uso, per emozionanti e conviviali momenti da vivere in serenità.

**The Oprah kitchen with its ornate frame door** with refined classical lines is designed for those that love the warmth and aesthetic solutions of traditional styles. Providing a touch of originality, it makes for highly unique and characteristic compositions. It also has a great sense of formal balance, generating a sense of satisfaction and ease of use, for serene moments of conviviality.

*Oprah*

# Area Tecnica

## TECHNICAL AREA

**Nelle prossime pagine** sono presenti le schede descrittive delle composizioni CREO Kitchens proposte in questo catalogo. Uno strumento per facilitarti nella scelta delle finiture, dei materiali, degli abbinamenti e delle dimensioni per un adeguato inserimento dei nostri prodotti nell'ambiente in cui verranno installati.

**The following pages** feature data sheets that describe the kitchen and living room compositions presented in this catalogue. This tool is designed to help you choose finishes, combinations and dimensions to allow you to correctly design your kitchen.

*Britt* pg. 38



Finiture e colori ante | Doors colours and finishes

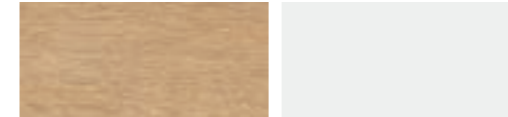

Rovere Miele  
Honey Oak

Bianco Lucido  
Glossy White

Finiture e colori top | Top colours and finishes



Laminato "ABS1" Nero fn. Flatting  
Laminate "ABS1" Black Flatting finish

Colori elementi a giorno | Open units colours



Bianco Assoluto  
Absolute White

Maniglia | Handle



K51

Tavolo | Table: Delta

Sedie e sgabelli | Chairs and stools: Newport

*Britt* pg. 42

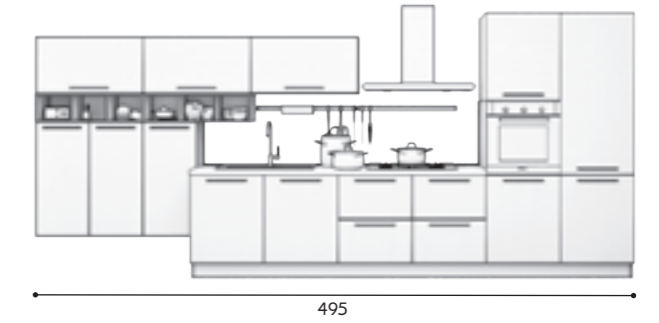

Finiture e colori ante | Doors colours and finishes

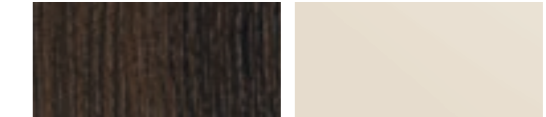

Olmo Cotto  
Burnt Elm

Beige  
Beige

Finiture e colori top | Top colours and finishes



Laminato Fenix Beige  
Laminate Fenix Beige

Colori elementi a giorno | Open units colours



Acquamarina  
Aquamarine

Maniglia | Handle



K52

Tavolo | Table: Spheric

Sedie e sgabelli | Chairs and stools: Chiara

*Gayla* pg. 30

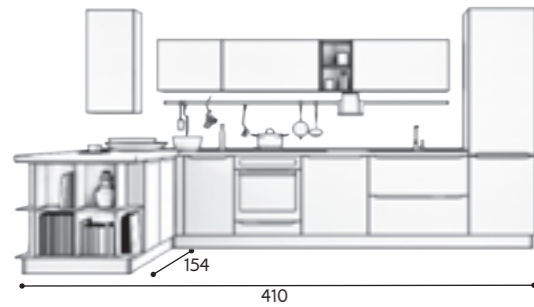

Finiture e colori ante | Doors colours and finishes



Olmo Grigio Spazzolato  
Brushed Elm Grey

Bruno Antilope  
Brown Antelope

Finiture e colori top | Top colours and finishes



Laminato Fenix Castoro  
Laminate Fenix Beaver

Colori elementi a giorno | Open units colours



Bruno Antilope  
Brown Antelope

Maniglia | Handle



960

Tavolo | Table: Moma

Sedie e sgabelli | Chairs and stools: Suren e Prix

## Mya pg. 70

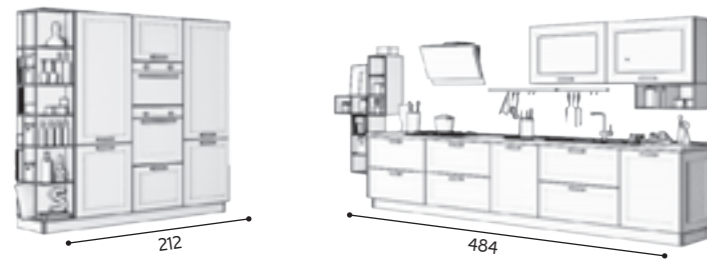

Finiture e colori ante | Doors colours and finishes

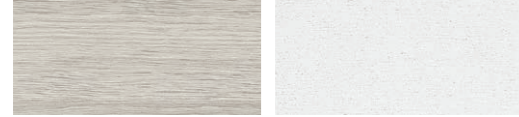

Larice Grigio Chiaro  
Light Grey Larch

Bianco Spazzolato  
Brushed White

Finiture e colori top | Top colours and finishes



Laminato "ABS1" Maya Bronza fin. Grafis  
Laminate "ABS1" Maya Bronza Grafis finish

Colori elementi a giorno | Open units colours



Giallo Ambra  
Amber Yellow

Maniglia | Handle



880

Tavolo | Table: Twin

Sedie e sgabelli | Chairs and stools: Chiara

## Mya pg. 74

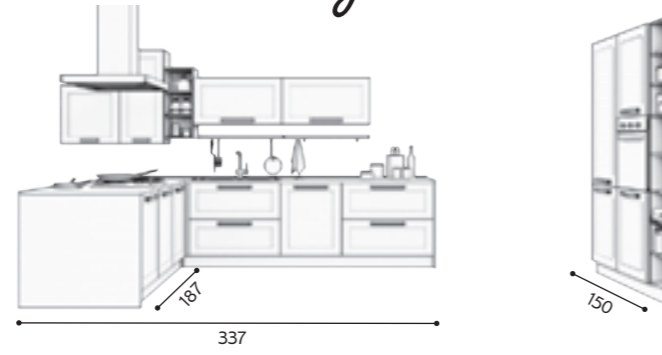

Finiture e colori ante | Doors colours and finishes



Larice Tabacco  
Tobacco Larch

Larice Sabbia  
Sand Larch

Finiture e colori top | Top colours and finishes

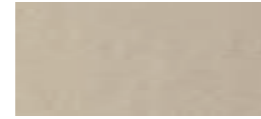

Laminato "ABS1" Corda fin. Plamky  
Laminate "ABS1" Rope Plamky finish

Colori elementi a giorno | Open units colours



Giallo Ambra  
Amber Yellow

Maniglia | Handle



F499

Tavolo | Table: Palomar 40

Sedie e sgabelli | Chairs and stools: Suren e Prix

## Selma pg. 78

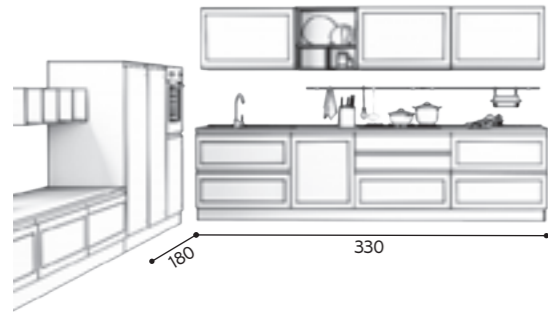

Finiture e colori ante | Doors colours and finishes



Frassino Laccato Bianco poro aperto  
Open-pore White laquered Ash

Finiture e colori top | Top colours and finishes



Laminato "ABS1" Grigio Chiaro fin. Plamky  
Laminate "ABS1" Light Grey Plamky finish

Colori elementi a giorno | Open units colours



Rosso Corallo  
Red Coral

Tavolo | Table: Ship

Sedie | Chairs: Tower

## Selma pg. 82



Finiture e colori ante | Doors colours and finishes



Frassino Laccato Canapa poro aperto  
Open-pore Hemp laquered Ash

Finiture e colori top | Top colours and finishes

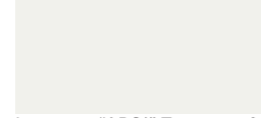

Laminato "ABS1" Travertino fin. Luna  
Laminate "ABS1" Travertine Luna finish

Colori elementi a giorno | Open units colours



Bianco Assoluto  
Absolute White

Tavolo | Table: King

Sedie e sgabelli | Chairs and stools: Arnica

## Zoe pg. 86

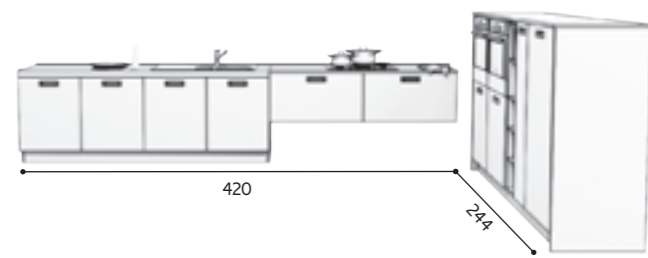

Finiture e colori ante | Doors colours and finishes



Grigio Antracite Lucido  
Glossy Anthracite Grey

Tortora Chiaro Lucido  
Glossy Light Dove Grey

Finiture e colori top | Top colours and finishes

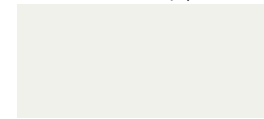

Light Bianco  
Light White

Colori elementi a giorno | Open units colours



Giallo Ambra  
Amber Yellow

Maniglia | Handle



940C ad incasso fin. cromo  
940C recessed chrome finish

Sedie | Chairs: Erica

## Zoe pg. 90



Finiture e colori ante | Doors colours and finishes



Visone Lucido  
Glossy Mink

Bianco Neve Lucido  
Glossy Snow White

Finiture e colori top | Top colours and finishes



Light Grigio Nube  
Light Cloud Grey

Colori elementi a giorno | Open units colours



Rosa Quarzo  
Quartz Pink

Maniglia | Handle



K01

Tavolo | Table: Yoga

Sedie | Chairs: Melissa

## Elin pg. 112

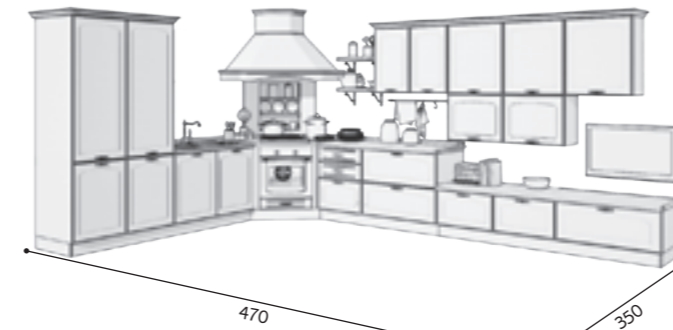

Finiture e colori ante | Doors colours and finishes

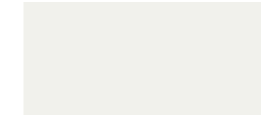

Bianco Assoluto Lucido  
Glossy Absolute White

Finiture e colori top | Top colours and finishes

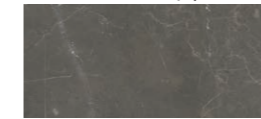

Marmo Emperador Vena Bianca Lucido profilo "S"  
Polished Emperador Marble White Vein profile "S"

Maniglia | Handle



K80

Tavolo | Table: Sinfonia

Sedie e sgabelli | Chairs and stools: Anthea

## Iris pg. 96

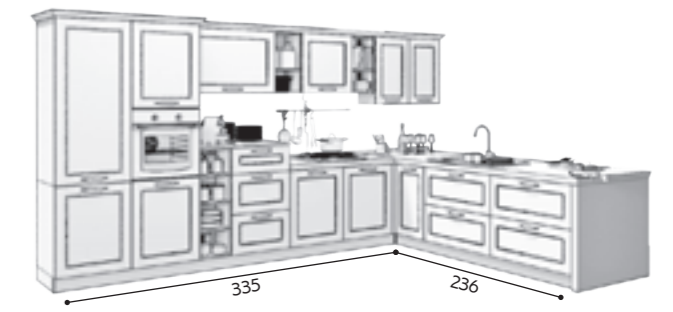

Finiture e colori ante | Doors colours and finishes



Bianco Camelia a poro aperto  
Open-pore Camelia White

Grigio Invecchiato  
Aged Grey

Finiture e colori top | Top colours and finishes



Light Beige Sabbia  
Light Beige Sand

Colori elementi a giorno | Open units colours



Bruno Antilope  
Brown Antilope

Maniglia | Handle



K82

Tavolo | Table: Delta

Sedie e sgabelli | Chairs and stools: Suren

## Malin pg. 104

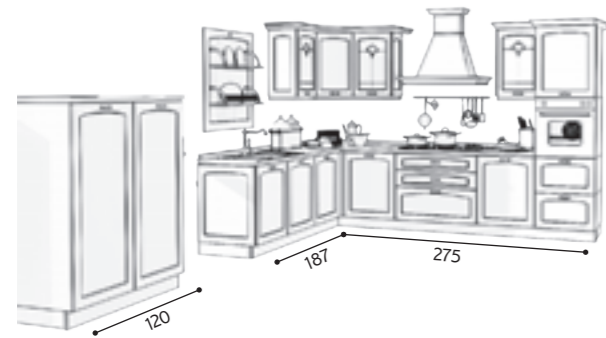

Finiture e colori ante | Doors colours and finishes



Tinto Castagno  
Chestnut-stained finish

Finiture e colori top | Top colours and finishes

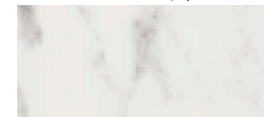

Marmo Bianco Carrara Spazzolato profilo "S"  
Brushed Carrara White Marble "S" Profile

Maniglia | Handle



170  
170

Tavolo | Table: Cleo

Sedie e sgabelli | Chairs and stools: Odea/Azalea

## Oprah pg. 116

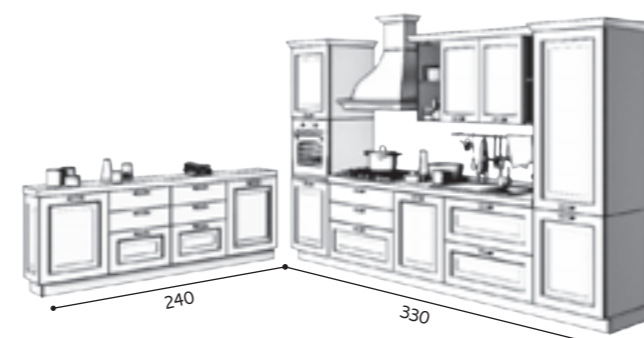

Finiture e colori ante | Doors colours and finishes



Tinto Noce  
Walnut-stained finish

Bianco Antico Decapè  
Pickled Antique White

Finiture e colori top | Top colours and finishes

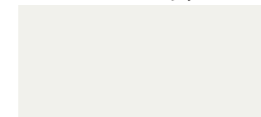

Light Bianco  
Light White

Maniglia | Handle



147  
147

Tavolo | Table: Musa

Sedie | Chairs: Azalea

## Raila pg. 100

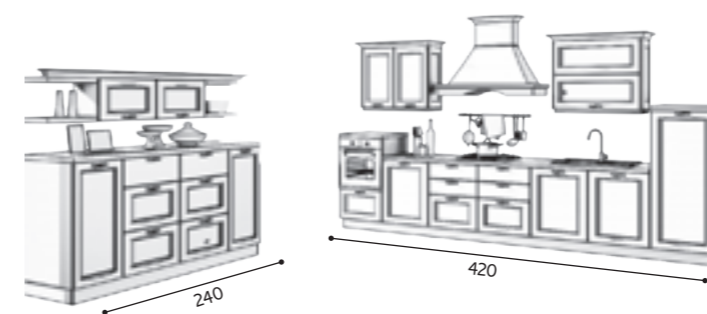

Finiture e colori ante | Doors colours and finishes

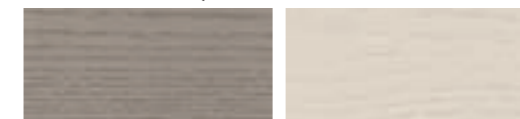

Grigio Polvere Poro Aperto  
Open-pore Dust Gray

Bianco Camelia Poro Aperto  
Open-pore Camelia White

Finiture e colori top | Top colours and finishes



Quarzo Bianco ma Lucido  
Polish White ma Quartz

Maniglia | Handle



172

Tavolo | Table: Dolcevita

Sedie e sgabelli | Chairs and stools: Azalea

## Vivian pg. 108

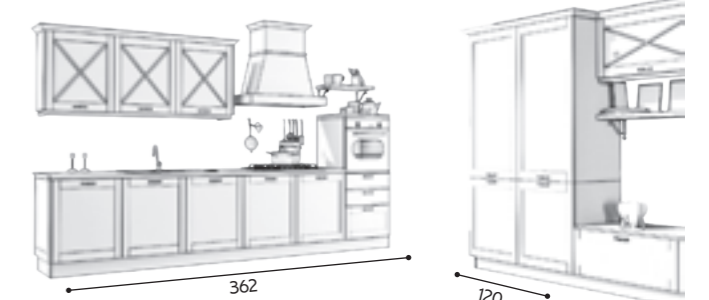

Finiture e colori ante | Doors colours and finishes



Decapato Tortora  
Pickled Dove Grey

Bianco Spazzolato  
Brushed White

Finiture e colori top | Top colours and finishes

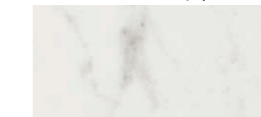

Marmo Bianco Carrara Spazzolato profilo "S"  
Brushed Carrara White Marble profile "S"

Maniglia | Handle



606

Tavolo | Table: Musa

Sedie e sgabelli | Chairs and stools: Azalea

# Elementi a Giorno

## OPEN UNITS

L'ultima tendenza nel mondo della cucina e del living è la riscoperta degli elementi a giorno, contenitori rivisitati in chiave contemporanea, che permettono di mettere in bella vista oggetti, libri, collezioni, decorazioni e accessori per soluzioni estetiche funzionali e creative. Nel mondo di Creo Kitchens sempre attento alle innovazioni, gli elementi a giorno vengono proposti in una vasta gamma di misure e colori.

The newest trend in kitchen and living room furniture is the rediscovery of open units. These containers have been given a contemporary reinterpretation and allow you to display objects, books, collectors' items, decorations and accessories, for functional and creative aesthetic solutions. The world of Creo Kitchens is always on the lookout for innovations and our open units are available in a vast range of sizes and colours.



### Elementi pensili orizzontali chiusi

Horizontal wall units

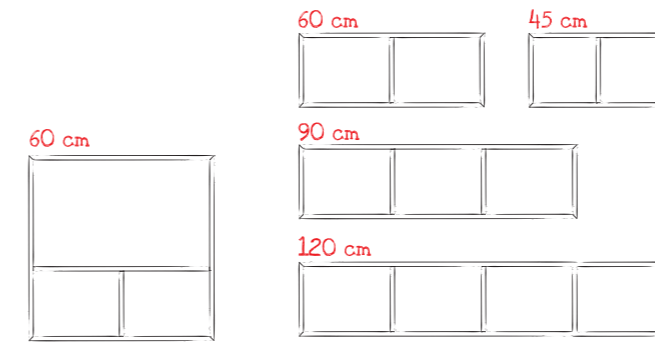

### Elementi pensili orizzontali aperti

Midway units

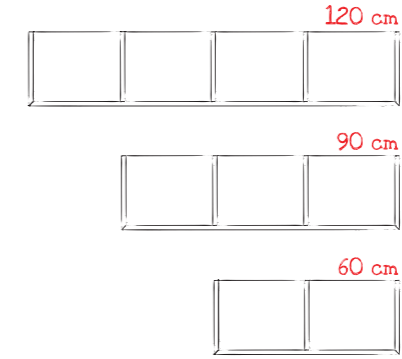

### Elementi pensili verticali

Vertical wall units

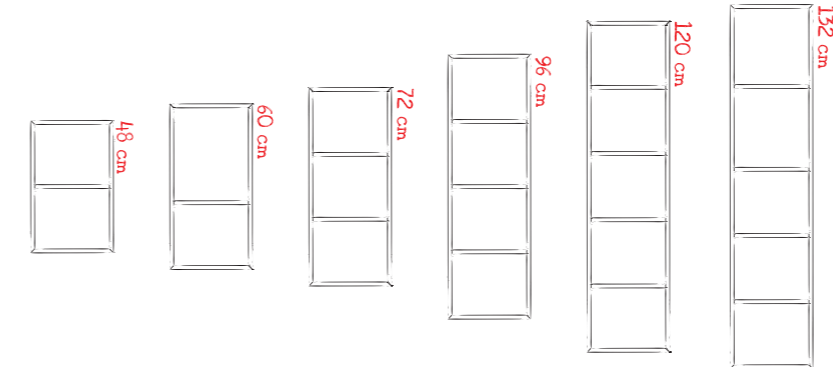

### Elementi per basi e colonne

Floor standing base units

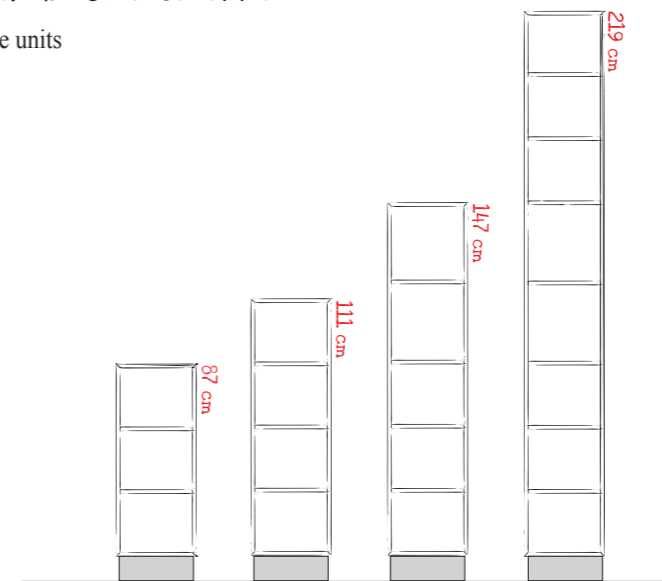

### Elementi terminali

End units

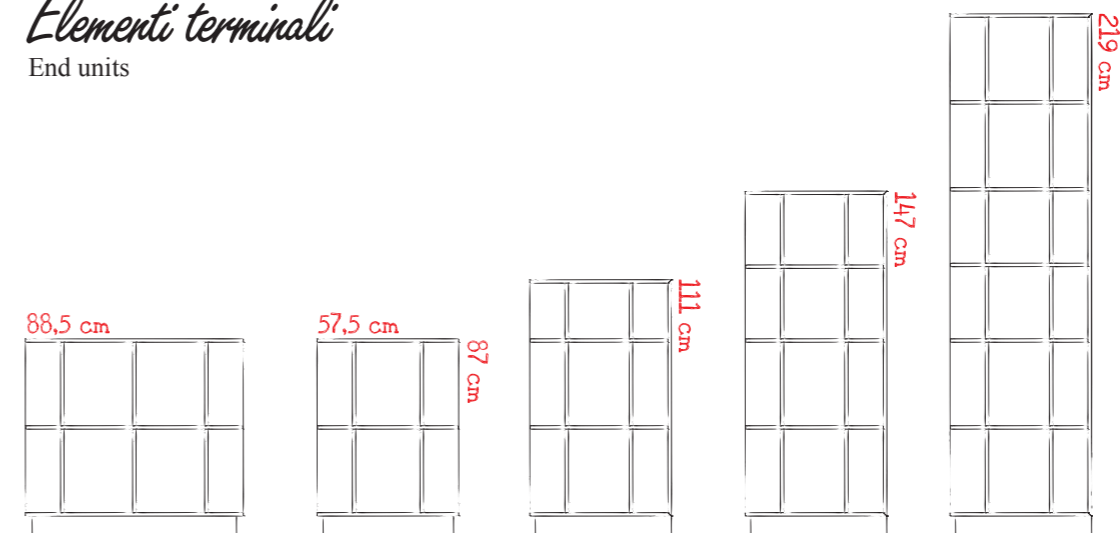

### Colori

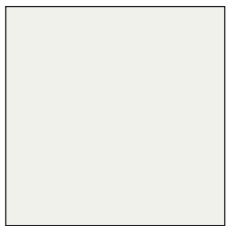

Bianco assoluto  
Absolute white

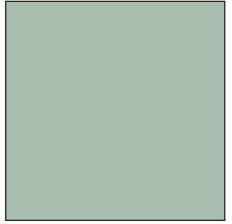

Salvia  
Sage

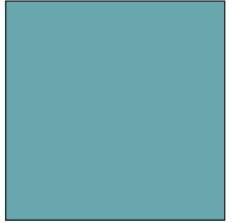

Acquamarina  
Aquamarine

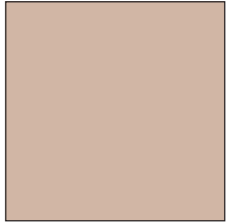

Rosa quarzo  
Quartz pink

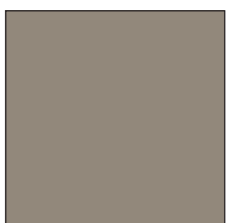

Bruno antilope  
Brown Antelope

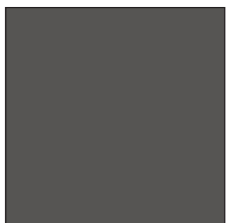

Vulcano  
Volcano

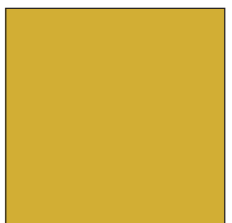

Giallo Ambra  
Amber yellow

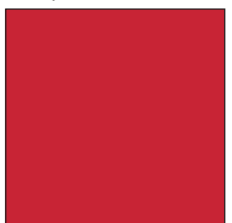

Rosso corallo  
Red Coral



# Materiali

## Melaminico



L'anta in melaminico nasce da un un pannello truciolare (o da altri composti a base di legni riciclati) grezzo rivestito in uno o due lati con carta melaminica, un materiale sintetico costituito da fogli di carta sottilissima (attorno al decimo di mm) impregnati di resina a base di melamina. L'uso di tale carta fa sì che il pannello nobilitato venga spesso chiamato pannello melaminico. Inizialmente utilizzato quale prodotto economico in sostituzione del "vero legno" o del laminato plastico, oggi grazie allo sviluppo di carte sempre più realistiche, che riescono a simulare i pori del legno creando delle rugosità, alle notevoli doti di durezza e resistenza al graffio ed ai solventi delle superfici, e alla facilità e velocità di lavorazione rendono questo prodotto molto apprezzato ed utilizzato nel mondo dell'arredamento.

**Per la pulizia di prodotti realizzati in laminato melaminico** si possono usare solo prodotti neutri (quindi ne acidi, come la candeggina, ne basici, come l'ammoniaca) che non contengano paste abrasive: si consiglia infatti di usare i prodotti per la pulizia dei vetri, strofinando quindi le ante con un panno morbido con l'ausilio di questi detergenti.

Creo Kitchen utilizza ante in laminato melaminico nei modelli Alma e Nita.

**La finitura Tranché melaminico** dona alla superficie dei mobili l'effetto materico del legno grezzo: una lavorazione dal sapore artigianale che conserva un tratto irregolare ed archetipo. Senza abdicare alla funzionalità e durabilità dei materiali, eleva la semplice superficie a strumento di sollecitazione visiva, tattile ed evocativa conservando l'impronta originale del legno. Questa superficie trova ampia applicazione nell'interior design di cucine e mobili per il living.

In Creo Kitchens questa particolare finitura viene utilizzata nei modelli Alma e Nita.

## Polimerico



Le ante in polimerico sono composte da un pannello in fibre di legno di media densità (MDF) la cui superficie viene rivestita con un materiale sintetico o PVC di spessore variabile che conferisce al pannello un'estetica gradevole e lo rende altamente resistente alle infiltrazioni dei liquidi e agli urti. I fogli polimerici possono essere in tinta unita o riportare la stampa del legno. Il Polimerico permette di rivestire in maniera continua sia la faccia frontale dell'anta sia i quattro bordi laterali.

**Per la pulizia di questo tipo di anta** si può usare un panno morbido e un prodotto detergente non abrasivo oppure un panno in microfibra. In caso di sporco più resistente, è possibile utilizzare spazzole morbide e spugne con detersivi liquidi non abrasivi o detergenti per vetri con aggiunta di acqua di solito il 50%. In presenza di macchie da calcare basta usare detergenti contenenti acido acetico, acido citrico, oppure, per le macchie più leggere, acqua tiepida. Non utilizzare pagliette in acciaio o di prodotti contenenti creme abrasive o detersivi in polvere.

In Creo Kitchens le ante in polimerico sono utilizzate nei modelli Britt e Inka.

## Impiallacciato



Le ante impiallacciate sono composte da un pannello in truciolare che viene ricoperto da un foglio di tranciato (impiallacciatura) di legno. Si definiscono tranciati dei sottili fogli di legno di spessore dai 3 ai 30 decimi di millimetro. I pannelli così ottenuti vengono sezionati e bordati con bordo in legno massello dello spessore 2-3 millimetri. Il tutto poi viene verniciato. I legni con cui si fabbricano i tranciati sono vari e così anche le finiture che si ottengono (chiamate con il termine essenza).

**Pulire delicatamente con un panno umido** ed asciugare con cura; evitare l'uso di detersivi e spray non specifici per il legno; asciugare in ogni caso eventuali gocce d'acqua e vapore per evitare scrostature di vernici in particolare sotto il lavello. Non utilizzare assolutamente prodotti contenenti solventi (acetone, ammoniaca, ecc).

In Creo Kitchens le ante impiallacciate sono utilizzate nei modelli Selma, Taimi, Iris, Malin, Raila e Vivian.

## Laccato UV



Un'anta si dice laccata quando, anziché venire rivestita con uno strato superficiale di legno o laminato, viene colorata con vernici di vario tipo. Le laccature hanno fatto negli ultimi anni passi da gigante, sia per praticità, per resistenza e per l'attenzione all'ambiente. Le laccature permettono la scelta fra vasti campionari di colori, su alcune produzioni si possono effettuare laccature a campione. La laccatura a velo con tecnologia UV, è realizzata su base acrilica per un'elevata stabilità nel tempo per superficie e colore. La finitura superficiale lucida ha elevate caratteristiche di resistenza ai graffi e usura unite ad un'ottima facilità di pulizia.

**Pulire con un panno morbido** e detergente liquido, risciacquare ed asciugare con cura; non utilizzare prodotti abrasivi o che contengano alcol o solventi (acetone, trielina o ammoniaca).

In Creo Kitchens le ante laccate sono utilizzate nei modelli Alma e Nita.

## Acrilico



L'acrilico è un prodotto uniformemente colorato nel suo corpo e lucido brillante o opaco profondo. Ecologico, riciclabile al 100%, atossico, rimane inalterato nel tempo sia nella struttura che nei colori che resistono ai raggi UV. Brillante, Elegante, Ecologico, Resistente. Quattro semplici aggettivi per risolvere il problema delle superfici lucide o opache in qualsiasi ambiente ovunque ci debba essere eleganza e perfezione. L'acrilico è perfettamente planare e stabile. Eventuali graffi possono essere eliminati con una semplice operazione di lucidatura. Le ante in acrilico sono costituite da un supporto di truciolare, rivestito nella parte a vista e nel retro da fogli di acrilico, i profili sono normalmente bordati con bordi in ABS.

**Non utilizzare su di esso i seguenti prodotti:** acetone, inchiostro ed etile-butile acetato. Eventuali graffi possono essere eliminati con una semplice operazione di lucidatura.

In Creo Kitchens le ante in acrilico sono utilizzate nel modello Zoe.

## Alkorcell



L'Alkorcell è costituito da una foglia decorativa a base polipropilene (PP) priva di componenti alogeni, plastificanti, e formaldeide. Essa è appropriata per il rivestimento di superfici di materiali a base legno e trova applicazione nella produzione di componenti per mobili. Una vernice termoindurente conferisce alla foglia le proprietà necessarie per queste applicazioni. Per la lavorazione con diversi sistemi di incollaggio, la foglia viene nobilitata a retro con un primer e l'incollaggio avviene con colle a dispersione o termofusibili o a solvente. Il laminato plastico Alkorcell è un materiale atossico che consente di abbattere totalmente le eventuali emissioni di formaldeide. Si tratta di un rivestimento plastico in continuo, totalmente privo di alogeni. E' sicuro, atossico, offre la massima sicurezza al contatto con i prodotti alimentari, è privo di odori e di sapori, con certificato di idoneità e di igiene. E' sicuro nella combustione, non produce gas tossici e corrosivi, ha una combustione del tutto simile a quella del legno con una produzione di fumi chiari, di conseguenza sicuro nell'eliminazione dei residui di lavorazione. E' impermeabile, infatti i manufatti protetti con Alkorcell resistono a umidità, muffe, microrganismi.

In Creo Kitchens le ante in Alkorcell sono utilizzate nei modelli Gayla e Mya.

# Materials

## Melamine



**Melamine doors** are made using a chipboard panel (or other type of composite made from recycled wood) coated on one or two sides with melamine paper. This is a synthetic material comprised of very thin sheets of paper (around one tenth of a mm) impregnated with a melamine-based resin. The use of this paper leads to the coated panel often being called a melamine panel. Initially used as an economical alternative to “real wood” or plastic laminate, it is now highly appreciated and widely used in the manufacture of furniture. This is largely thanks to the development of ever increasingly realistic papers, which are able to simulate the pores of natural wood, creating rough finishes. Melamine surfaces are very long lasting and highly scratch-resistant and solvents, as well as being very quick and easy to manufacture.

**Products made from melamine** laminates should only be cleaned using neutral detergents (i.e. neither acidic such as bleach, nor alkaline such as ammonia), which do not contain abrasive pastes: we recommend the use of detergents for cleaning glass, rubbing the doors with a soft cloth dampened with one of these products.

Creo Kitchens uses melamine laminate doors for models Alma and Nita.

**The Tranché finish** gives the surfaces of the cabinets the textured effect of rough wood: a manufacturing process with a handcrafted flavour that preserves an irregular and archetypal line. Without compromising the functionality and durability of the materials, it elevates surfaces to a level of visual, tactile and evocative stimulus that preserves the original fingerprint of wood. This surface is widely used in interior design for kitchens and living room furniture.

At Creo Kitchens this special finish is used for models Alma and Nita.

## Polymer



**Polymer coated doors** are comprised of a medium density wood fibre panel (MDF) whose surface is coated with a synthetic material or PVC. This coating may be of variable thickness and gives the panel a pleasant appearance as well as making it highly resistant to liquid penetration and knocks. Polymer sheets can either have solid colours or wood-grain effects. Polymer coating allows the front surface of the door as well as the four side edges to be coated in a continuous manner.

**This type of door can be cleaned** using a soft cloth dampened with a non-abrasive detergent or a micro fibre cloth. In the event of more stubborn dirt, use a soft brush or sponge with a non-abrasive liquid detergent or glass detergent diluted 50% with water. In the event of limescale deposits use a detergent that contains acetic acid, citric acid, or, for lighter deposits, warm water. Do not use steel cleaning pads or products that contain abrasive creams or powdered detergents.

At Creo Kitchens polymer coated doors are used for models Britt and Inka.

## Veneered



**Veneered doors** are comprised of a chipboard panel that is covered with a sheet of wood veneer. Sheets of veneer are very thin sheets of wood ranging from 3 to 30 tenths of a millimetre in thickness. Panels made in this way are then cut and edged with solid wood 2-3 millimetres thick. The panel is then varnished. Many different woods are used to make sheets of veneer and thus the finishes achieved can vary greatly (the name of the wood type is also used to define the type of veneer).

**Clean gently** using a damp cloth and dry thoroughly; do not use detergents and sprays which are not specifically designed for wood; dry any water droplets or steam to avoid damaging the varnish, particularly under the sink. Do not use products that contain solvents (acetone, ammonia, etc.).

At Creo Kitchens veneered panel doors are used for models Selma, Taimi, Iris, Malin, Raila and Vivian.

## UV lacquered



**A door is considered as lacquered** when, instead of being coated with a surface layer of wood or laminate, it is instead coloured with various types of paint. Lacquer finishes have made huge advances in the last few years, in terms of practicality, strength and environmental protection. Lacquer finishes provide a vast choice of colours and some models can be lacquered to match samples. Flow lacquer coating using UV technology is carried out on acrylic bases in order to provide stability over time for both the surface and colour coating. The glossy surface finish is highly scratch-resistant and wear and is very easy to clean.

**Clean using** a soft cloth and liquid detergent, then rinse and dry carefully; do not use abrasives or products containing alcohol or solvents (acetone, triline or ammonia).

At Creo Kitchens lacquered doors are used for models Alma and Nita.

## Acrylic



**Acrylic** is a product that is uniformly coloured throughout its structure and can be either highly polished or have a deep matt finish. Ecological, 100% recyclable and non-toxic, it does not change over time either in terms of structure or colour (UV resistant). Bright, Elegant, Ecological, Strong. Four simple adjectives to resolve the problem of glossy or matt surfaces in any environment that requires elegance and perfection. Acrylic is perfectly flat and stable. Any scratches can be eliminated by simply polishing. Acrylic doors are made from a chipboard support, which is coated with sheets of acrylic on the inside and outside. The edges of the panel are coated with strips of ABS.

**Do not use** any of the following products: acetone, ink or ethyl butyl acetate. Any scratches can be eliminated by simply polishing.

At Creo Kitchens acrylic doors are used for the Zoe model.

## Alkorcell



**This consists** of a polypropylene (PP) decorative sheet that does not contain halogens, plasticizers or formaldehyde. It is suitable for coating wood-based surfaces and is used in the production of cabinet components. A thermosetting lacquer gives the sheet the required properties for these applications. When working with different gluing systems, the sheet is faced on the back with a primer and gluing takes place using dispersion, hot-melt or solvent adhesives. Alkorcell plastic laminate is a non-toxic material with no formaldehyde emissions. It is a continuous plastic coating that is completely halogen free. It is safe, non-toxic, provides the maximum level of safety when in contact with food products and has no odour or flavour. It is certified as being fit for purpose and hygienic. It is combustion safe and does not produce toxic or corrosive gases. It combusts in a very similar way to wood, creating light coloured fumes. It is therefore also safe to dispose of manufacturing residues. It is waterproof, in fact objects protected with Alkorcell are resistant to damp, mould and microorganisms.

**Clean using** a soft cloth and liquid detergent, rinse and dry thoroughly. Do not use abrasive or aggressive products that contain alcohol or solvents. We recommend avoiding the use of products that contain diluents or acetone because they may cause deformation or softening.

At Creo Kitchens Alkorcell doors are used for models Gayla and Mya.

# Finiture & Colori

## COLOURS&FINISHES

La vasta gamma proposta da CREO Kitchens di finiture superficiali, dall'aspetto tattile e visivo, raffinato e seducente e dei colori declinati in proposte attuali ed emozionali, permettono di creare l'identità della tua cucina. Tatto e vista interagiscono nella personalizzazione del tuo ambiente cucina.

The vast range of surface finishes offered by Creo Kitchens, with refined tactile and visual qualities and contemporary and exciting colours allow you to create your kitchen's identity. Touch and sight interact to customise your kitchen area.

## Britt

Anta in MDF rivestito in polimerico / Polymer coated MDF door

### Finiture Legno / Wood Finish



Olmo cotto retro in tinta  
Burnt elm internal side finished as front door



Olmo naturale retro in tinta  
Natural elm internal side finished as front door



Rovere miele retro in tinta  
Honey oak internal side finished as front door

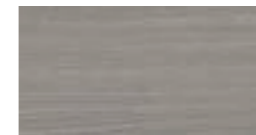

Rovere cenere retro in tinta  
Ash oak internal side finished as front door

### Finiture Opache / Matt Finish



Beige retro in tinta  
Beige internal side finished as front door



Grigio seta retro in tinta  
Silk grey internal side finished as front door

### Finiture Lucide / Glossy Finish



Rosso ferrari retro in tinta  
Ferrari red internal side finished as front door

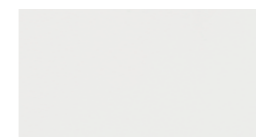

Bianco retro in tinta  
White internal side finished as front door



Tortora scuro retro in tinta  
Dark dove grey internal side finished as front door

## Gayla

Anta in Alkorcell / Alkorcell door

### Finiture Legno / Wood Finish



Olmo grigio spazzolato  
Brushed elm grey



Larice cappuccino spazzolato  
Brushed larch cappuccino



Larice bianco finitura melinga  
White larch with melinga finish

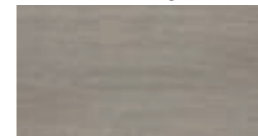

Rovere cenere finitura melinga  
Oak ash with melinga finish

### Finiture Opache / Matt Finish



Bruno antilope  
Antilope brown

# Zoe

Anta in acrilico / Acrylic coating door

*Ante Acrilico Lucido / Glossy Acrylic Door*

			
Bianco neve Snow white	Senape Mustard	Verde muschio Moss green	Grigio Grey
			
Ciclamino Cyclamen	Nuvolari Nuvolari grey	Fango Mud	Visone Mink
			
Giallo moscato Muscat yellow	Tortora chiaro Light dove grey	Lavanda Lavender	Blu vetro Glass blue
			
Grigio antracite Anthracite grey	Bordeaux Maroon		

*Ante Acrilico Opaco / Matt Acrylic Door*

			
Bianco assoluto Absolute white	Avorio Ivory	Tortora chiaro Light dove grey	Caffè Coffee
			
Visone Mink	Nero Black	Giallo moscato Muscat yellow	Melanzana Aubergine
			
Lavanda Lavender	Carta da zucchero Sugar paper	Grigio antracite Anthracite grey	

# Vetri

*Colori vetri / Glass Colours*

	
Bianco neve Snow white	Lavanda Lavender
	
Avorio Ivory	Rosso chiaro Light red
	
Giallo ambra Amber yellow	Visone Mink
	
Sabbia Sand	Caffè Coffee
	
Corda Jute	Grafite Graphite
	
Blu oltremare Ultramarine blue	Blu aviazione Aviation blue

## Mya

Anta a telaio in Alkorcell / Alkorcell framed door



Bianco spazzolato  
Brushed white

Brown spazzolato  
Brushed brown

Pergamena spazzolato  
Brushed parchment



Larice sabbia  
Sand larch

Larice grigio chiaro  
Light grey larch

Larice tabacco  
Tobacco larch

## Selma

Anta a telaio in massello di frassino / Solid Ash framed door



Frassino laccato bianco a poro aperto  
Open-pore white lacquered ash

Frassino laccato canapa a poro aperto  
Open-pore hemp lacquered ash

Frassino laccato visone a poro aperto  
Open-pore mink lacquered ash

## Elin

Anta a telaio in mdf rivestito in polimerico / Framed door with polymer coating



Bianco antico  
Antique white

Bianco assoluto lucido  
Glossy absolute white

## Oprah

Anta a telaio in legno massello / Solid wood framed door



Tinto noce  
Walnut-stained finish

Bianco antico decapè  
Pickled antique white

## Iris

Anta a telaio in massello di frassino / Solid Ash framed door



Bianco Camelia a poro aperto  
Open-pore camelia white

Argilla invecchiato  
Aged clay

Grigio invecchiato  
Aged grey

Bianco camelia a poro aperto  
Open-pore camelia white

Corda decapè a poro aperto  
Open-pore pickled jute

Grigio polvere a poro aperto  
Open-pore dust grey

## Raila

Anta a telaio in massello di frassino / Solid Ash framed door

## Malin

Anta a telaio in legno massello / Solid wood framed door



Tinto castagno  
Chestnut-stained finish

Bianco decapè a poro aperto  
Open-pore pickled white

## Virian

Anta a telaio in massello di abete / Solid Fir framed door



Bianco spazzolato  
Brushed white

Decapato mielato  
Pickled honey

Decapato tortora  
Pickled dove grey

CREO®  
KITCHENS

Progettazione e AD:  
uff. ricerca e sviluppo Lube Service&Engineering s.r.l.  
PHOEM Design

Realizzazione grafica:  
uff. marketing Lube Service&Engineering s.r.l.  
PHOEM Design

3D rendering:  
PHOEM Design  
1FRAMERENDER

Selezioni e stampa:  
OGM

I campioni e i colori riprodotti sono puramente  
indicativi, la rappresentazione in stampa può  
alterare la tonalità dei colori, le misure sono di  
massima, per qualsiasi riferimento vedi listino  
prezzi.

The samples and colours reproduced here  
are purely indicative as their representation  
in print can change the shades of the colours.  
Measurements are approximate, see the price  
list for all references.

L'azienda è a disposizione degli aventi diritto  
per le eventuali fonti iconografiche non  
identificate.

The company is at the disposal of those  
entitled to any iconographic sources not  
identified.



#### CREO ECOLOGIC

IL GRUPPO LUBE HA SCELTO DI UTILIZZARE PER I COMPONENTI  
COSTITUENTI LE STRUTTURE DELLE CUCINE SOLO MATERIALE A  
BASSISSIMA EMISSIONE DI FORMALDEIDE: CONFORMI ALLO  
STANDARD F4STELLE SECONDO LA NORMA JIS, CERTIFICATO DAL  
MINISTERO GIAPPONESE, IL PIÙ SEVERO IN MERITO ALLE NORMATIVE  
DI SALVAGUARDIA AMBIENTALE.

